

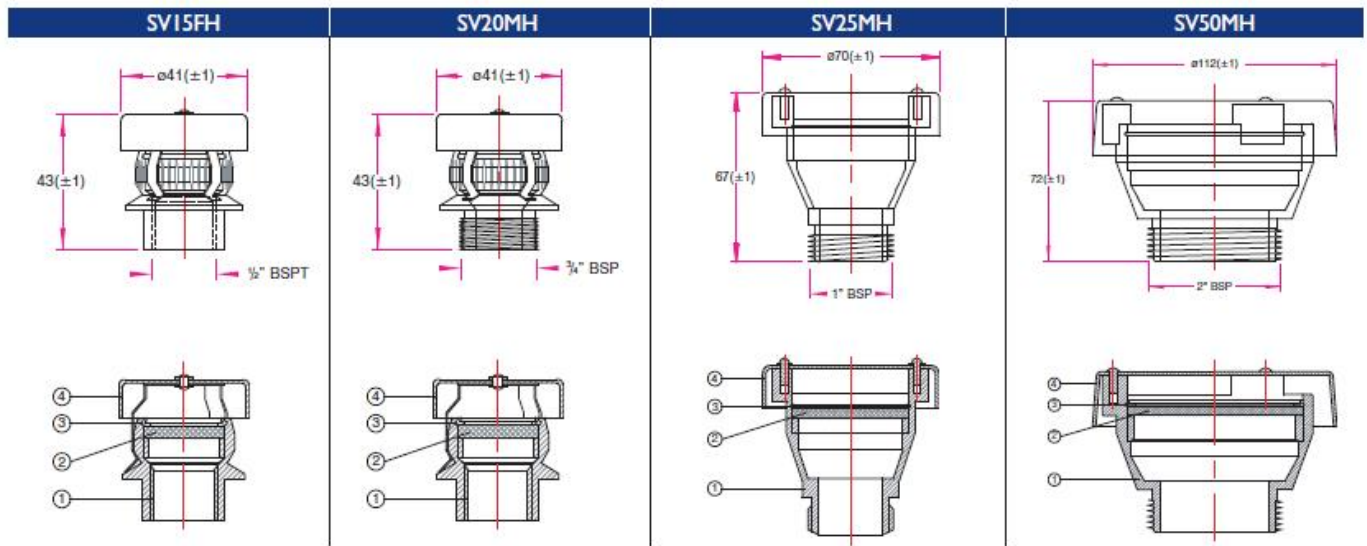

# SV Series

## Light Duty End of Line Flame Arresters with Fixed Elements

Drawings:



### Material Specifications

Ref	Description	SV15FH	SV20MH	SV25MH	SV50MH
1	Body	Mazak 3 Zinc Alloy	Mazak 3 Zinc Alloy	Mazak 3 Zinc Alloy	LM6 Aluminium Alloy
2	Element Core	316L Stainless Steel	316L Stainless Steel	316L Stainless Steel	316L Stainless Steel
3	Element Core Retaining Ring	Aluminium	Aluminium	Aluminium	Aluminium
4	Weatherhood	Aluminium	Aluminium	Aluminium	Aluminium

### Model Specifications

NB (mm)	Model Number (with weatherhood)	Model Number (without weatherhood)	Screw Connection	Approximate Weight (kg)	ø Element (mm)
15	SV15FH	SV15F	1/2" BSPT female	0.1	25
20	SV20MH	SV20M	3/4" BSP male	0.1	25
25	SV25MH	SV25M	1" BSP male	0.2	44
50	SV50MH	SV50M	2" BSP male	0.3	79

### SV Flow Curves

Air flow at 1atmosphere (101.325kPa) and 0°C

